



CLYDE & CO

Successful risk navigation

# Case Studies in Engineering and Ethical Failures

Vanessa Reakes

December 4, 2025

# Kansas City Hyatt Walkway Collapse

(Beware of Field Changes)



## Kansas City Hyatt Walkway Collapse (Cont.)

- The 40 story Hyatt Regency in Kansas City was constructed in 1978-1980.
- The atrium lobby had several suspended walkways at the second, third and fourth floor levels.
- The fourth-floor walkway was suspended directly over the second-floor walkway; the third-floor walkway was offset.
- 1600 people were in the lobby on July 17, 1981 to participate in and watch a "tea dance".
- Many stood on the walkways to watch the dance on the floor of the lobby.
- The fourth-floor walkway collapsed onto the second-floor walkway, which in turn collapsed onto the floor. 114 lives were lost.

## Kansas City Hyatt Walkway Collapse (Cont.)



# Kansas City Hyatt Walkway Collapse (Cont.)

**Design change suggested by contractor during construction for ease of fabrication**

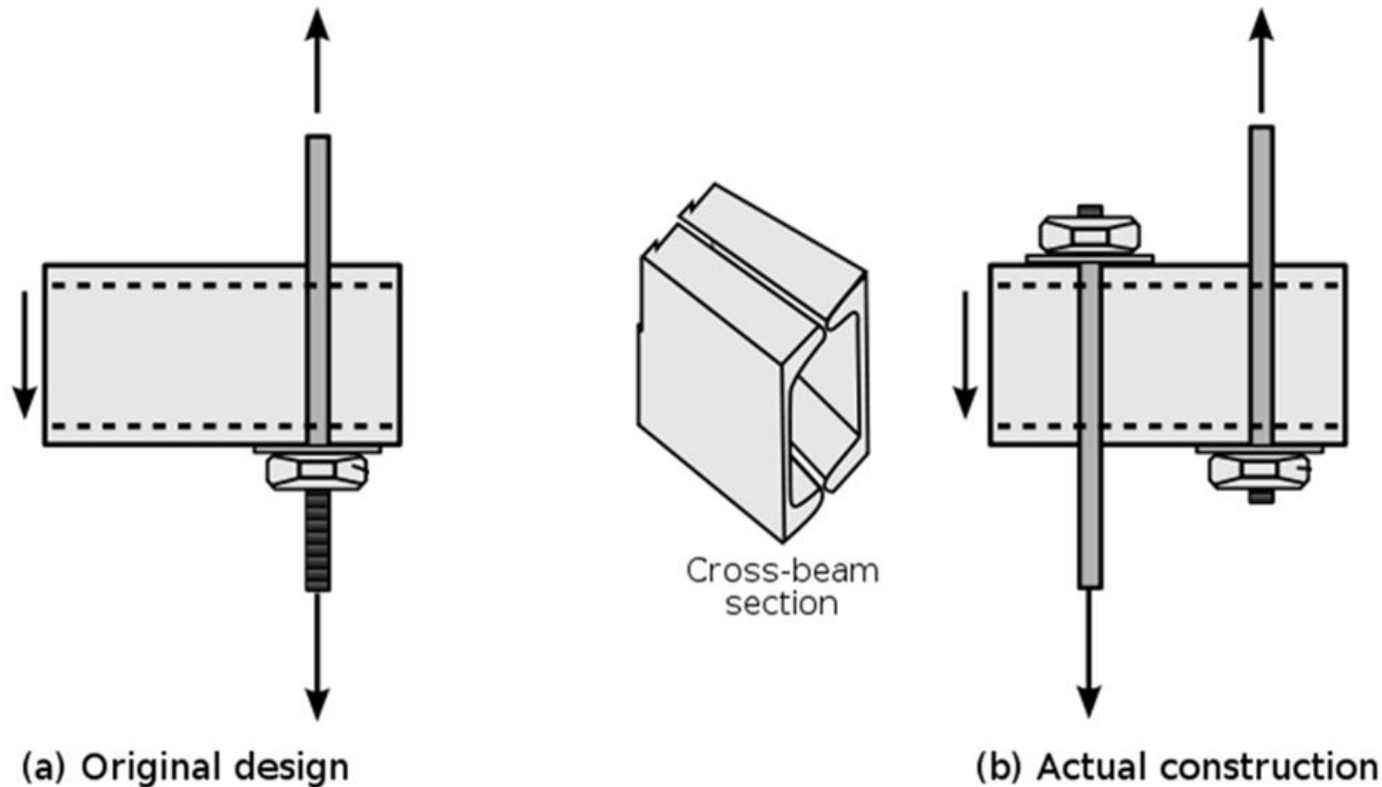

# Kansas City Hyatt Walkway Collapse (Cont.)

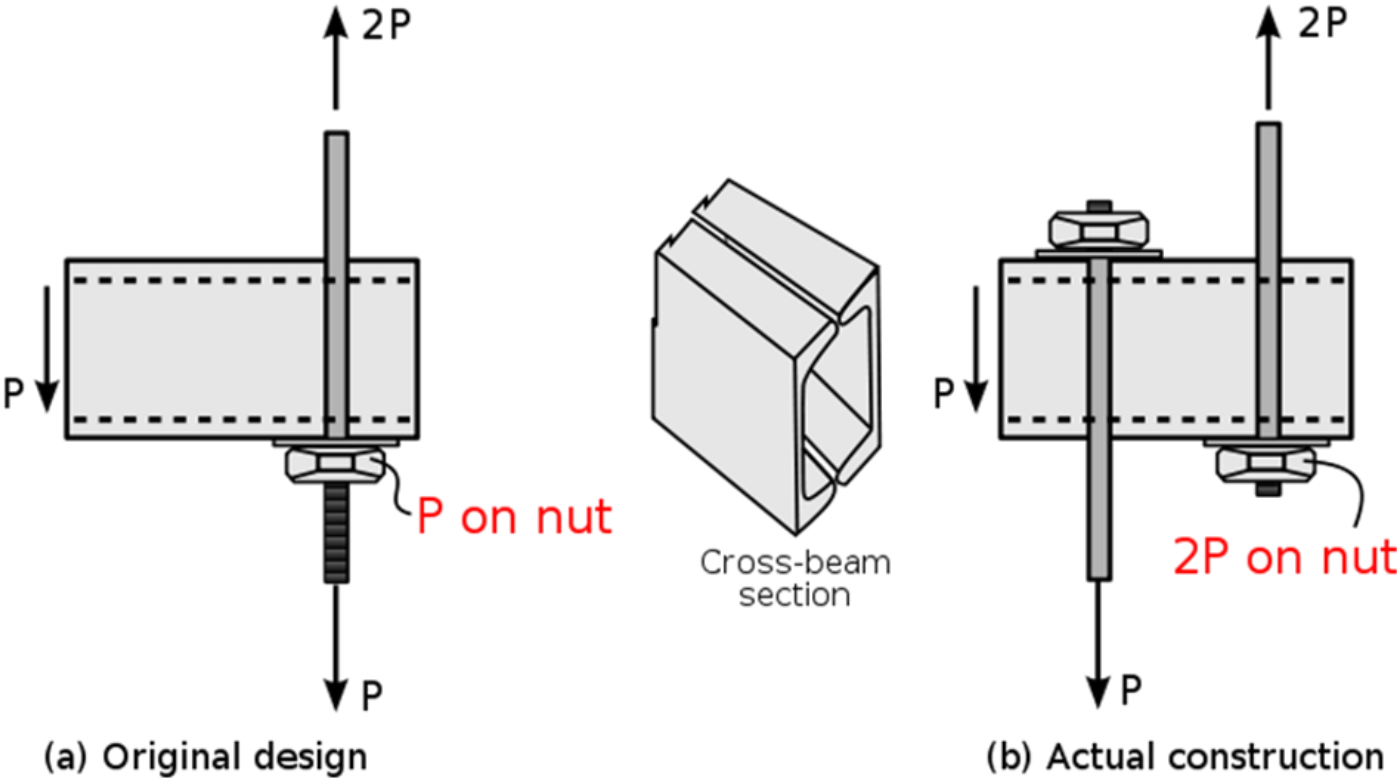

## Kansas City Hyatt Walkway Collapse (Cont.)

- The result was that the load on the nuts holding the fourth-floor walkway doubled, with tragic results.
- As a result of various hearings and lawsuits, several engineers lost their licenses, firms went bankrupt, and lives were ruined.

## Kansas City Hyatt Walkway Collapse (Cont.)

- Fabricator claims to have phoned the design engineer to approve the change.
- The design engineer denied ever receiving such a call.
- There was no documentation of the change, other than a shop drawing showing the revised configuration, which was provided in a package of 42 shop drawings.
- The connections were not adequately detailed on the shop drawings, and the fabricator had not performed calculations on the connections.
- The design engineer assigned review of the shop drawings to a technician on his staff; the technician performed no calculations on the connections.
- The design engineer testified at hearing that it was common industry practice for the structural engineer to leave the design of steel-to-steel connections to the fabricator.
- The design engineer performed "spot checks" on portions of the shop drawings and approved them.

# Kansas City Hyatt Walkway Collapse (Cont.)

## Discussion

- Multiple causes, multiple responsibilities;
- Insufficient attention given to changes during construction;
- Insufficient attention given to crucial structural components;
- Inadequate checking of crucial structural components;
- Inadequate communication;
- Inadequate documentation of communication;
- Inadequate field review; and
- Inadequate intuition – "feel" the job.

## Kansas City Hyatt Walkway Collapse (Cont.)



# DC-10 Cargo Door

(When do you blow the whistle?)



## DC-10 Cargo Door (Cont.)

- The DC-10 was McDonnell Douglas' answer to Boeing's 747.
- Developed in the late 1960s, the DC-10 began flying in 1970 and entered commercial service in 1971.
- On March 3, 1974, Turkish Airlines flight 981, a DC-10 flying out of Paris experienced an explosive decompression 10 minutes after takeoff when a rear cargo door burst open.
- The resulting differential in pressure between the passenger and cargo compartments collapsed the floor, severing the hydraulic control lines that ran within the floor.
- The aircraft crashed and 346 people were killed.
- DC-10 cargo doors had failed prior to this crash – both doors blew off in 1970 during a ground test and the American Airlines flight had experienced a similar explosive decompression over Windsor, Ontario in 1972. The American Airlines flight landed safely, however.

# DC-10 Cargo Door (Cont.)

## Design Philosophy

- Passenger doors are "plug type" (inward-opening) – pressure prevents door from opening.
- Cargo doors have to open outward, but pressure would assist in keeping the latches closed.
- Incomplete closure would result in pressure forcing the latches open.

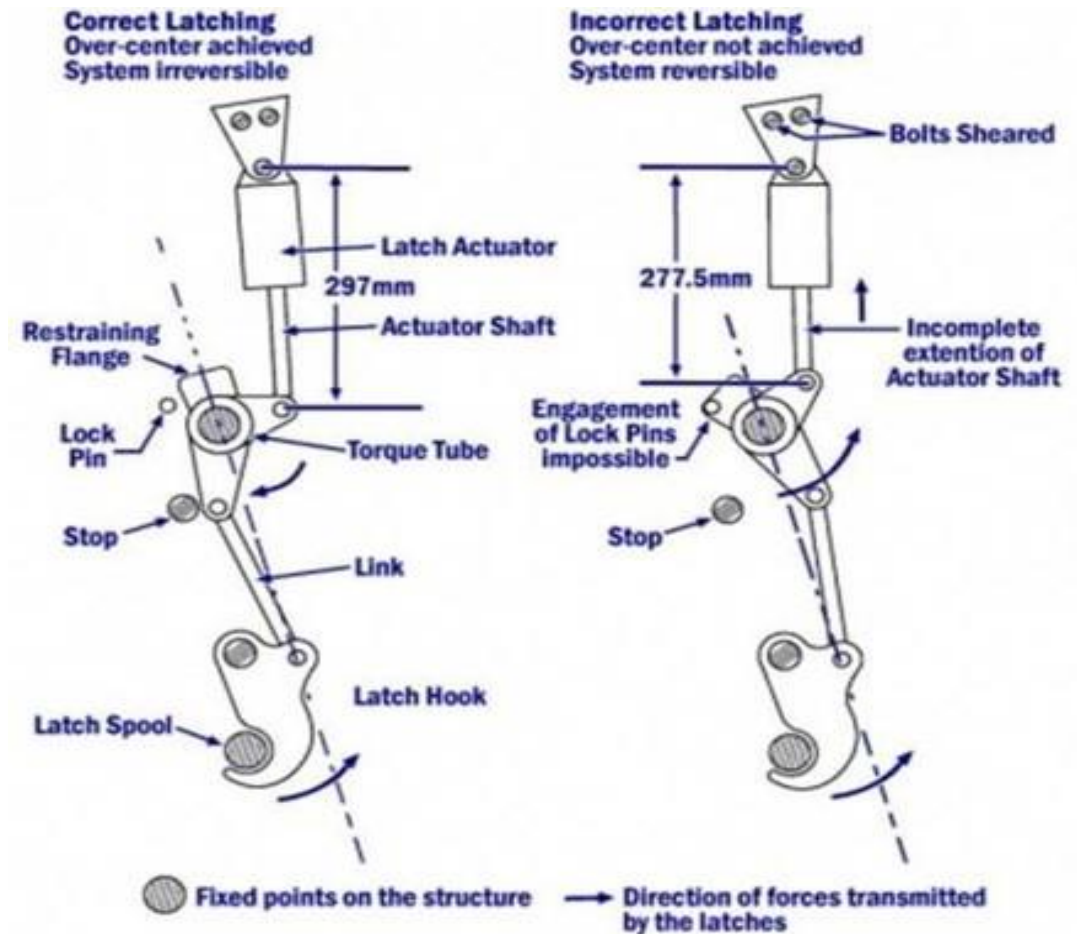

## DC-10 Cargo Door (Cont.)

### The Choice of Actuator was Critical

- Hydraulic actuator constantly applies pressure and, in the event of incomplete closure, would fail when the pressure offsets the (fairly low) actuator force.

Result: the cargo door would open under relatively small pressure differential, the aircraft will not pressurize and would have to land.

- An electric actuator turns off after use and hard ratchets hold the latches in position; failure occurs only once the pressure is sufficient for the ratchet to fail.

Result: the cargo door failed under much greater differential pressure, resulting in collapse of the floor and loss of the aircraft.

- Design engineer favoured the hydraulic actuator for this reason, but was overruled because of lower weight and ease of maintenance on the electric actuator.

## DC-10 Cargo Door (Cont.)

### Failure During Ground Test

- The exact failure mode of both the American Airlines and Turkish Airlines incidents occurred on the ground in 1970 during a pressure test.
- The incident was blamed on the mechanic failing to properly close the door and a series of small modifications were made to the door, including an indicator showing the ground crew when the cargo door was properly closed.
- The fundamental vulnerability of a differential in pressure resulting in a failure of the floor, the severing of the hydraulic control lines, and the resulting loss of control of the aircraft was not addressed.

## DC-10 Cargo Door (Cont.)

### **American Airlines Flight 96**

- Two circumstances save the American Airlines flight.
- First, with only 36 people on board, the floor was very lightly loaded and did not completely collapse; not all hydraulic lines were severed.
- Secondly, Capt. McCormick was extremely skilled, and had spent time in a simulator learning to fly a plane using only throttles and wing control surfaces in the event that he ever lost control of the rear surfaces; he had practiced for exactly this event.

## DC-10 Cargo Door (Cont.)

### Failures in Communication

- Following the American Airlines flight 96 incident, Dan Applegate, Director of Product Engineering at Convair wrote a memo to his boss.
- He said that the fundamental safety of the cargo door was being progressively degraded.
- He said the airplane demonstrated an inherent susceptibility to catastrophic failure when exposed to explosive decompression - i.e. the unvented passenger floor.
- He noted how the baggage loader in Detroit had forced the cargo door shut which caused the improperly latched door to blow off the airplane, very nearly resulting in its loss.

## DC-10 Cargo Door (Cont.)

### Failures in Communication (Cont.)

- Applegate called McDonnell Douglas' service bulletins “Band-aid fixes” and predicted the loss of other aircraft because of their shortcomings and because of the decision to not cut vents in the passenger compartment floor above the aft cargo door.
- Applegate made a compelling argument that even if the door fixes were fool-proof (which he argued they were not), the decision to not address the floor problems left the aircraft vulnerable to explosive decompression and total loss of control in the event of a bomb, mid-air collision or other event unrelated to the cargo door itself.
- “It seems to me inevitable that, in the 20 years ahead of us, DC-10 cargo doors will come open and I would expect this to usually result in the loss of the airplane”.
- Applegate's bosses did not act on the memo because they thought it would harm Corvair's relationship with McDonnell Douglas.

## DC-10 Cargo Door (Cont.)

### **Modifications After American Airlines Flight 96**

- Two principal modifications were proposed:
  - A peephole through which a baggage handler could visually confirm proper position of a locking pin; and
  - A support plate which would prevent a torque tube from bending and allow “false closing” of the door.
- Failure to convey the urgency of these modifications, and a failure on the part of the FAA to ground the aircraft until they were carried out, resulted in the second modification never having been done to the Turkish Airlines aircraft.

# DC-10 Cargo Door (Cont.)

## Ethical Considerations

- Should Applegate have blown the whistle?
- Should Convair have raised the Applegate memo with McDonnell Douglas?
- Should McDonnell Douglas have looked more closely at the fundamental flaw – the vulnerability of the hydraulic lines?
- (The routing of the hydraulic lines was a McDonnell Douglas decision, and it is easier to blame Convair for its door design.)

# Ford Pinto



# Ford Pinto

- Crash tests of prototypes showed that the Pinto would not withstand standards proposed by the National Highway Traffic Safety Administration (NHTSA) which would require cars to survive a 20 mile-per-hour impact without leaking fuel.
- A modification (a rubber bladder), estimated to cost \$11 per vehicle, would prevent the loss of fuel.
- The modification would push back the introduction of the Pinto.
- Ford decided to bring the car to market without the modification.

## Ford Pinto (Cont.)

### **Cost Benefit Analysis**

- Ford had an internal report entitled "Fatalities Associated with Crash-Induced Fuel Leakage and Fires" (the report was not specific to the Pinto, and concerned fuel leakage in rollover accidents, not rear end collisions, but it illustrates the rationale).
- At the time, the law valued a life at \$200,000.
- At the time, the law valued serious burn injuries at \$67,000.
- Ford anticipated selling 11 million Pintos and, based on this statistic, Ford anticipated 180 burn deaths and 180 serious burn injuries.

# Ford Pinto (Cont.)

## Cost Benefit Analysis (Cont.)

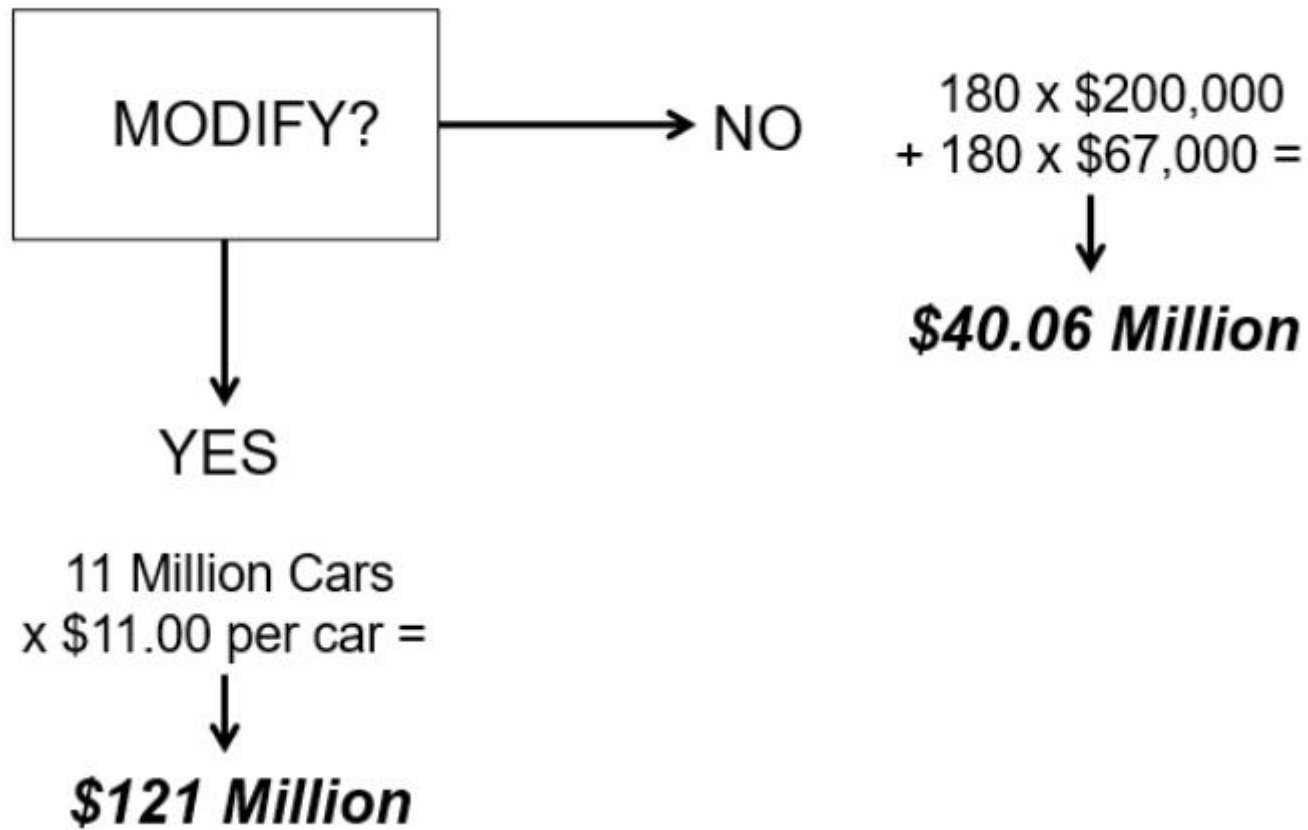

## Ford Pinto (Cont.)

### **Economic Theory of Negligence (Learned Hand Rule)**

- The defendant's duty to protect against injuries is a function of three variables:
  - (1) The probability of the accident;
  - (2) the gravity of the resulting injury;
  - (3) the burden of adequate precautions.
- This relationship has been formalized as:  $PL > B$
- B is the cost (burden) of taking precautions, P is the probability of loss and L is the gravity of loss.
- The product of P and L must be a greater amount than B to create a duty of care.

## Ford Pinto (Cont.)

### **Punitive Damages**

- Generally, damages are intended to compensate the victim of a tort (negligence).
- Courts can and do award punitive damages, which are intended to punish the defendant, rather than compensate the plaintiff.
- Courts impose punitive damages (also called aggravated damages) in cases where the court finds that a defendant's conduct has been "high-handed, malicious or reprehensible".
- Punitive damages skew the decision tree.
- Problem: since judgments are retrospective, there is no way to know in advance what the punitive judgment would amount to.

# Culvert Failure

Exposure for Failure to Warn

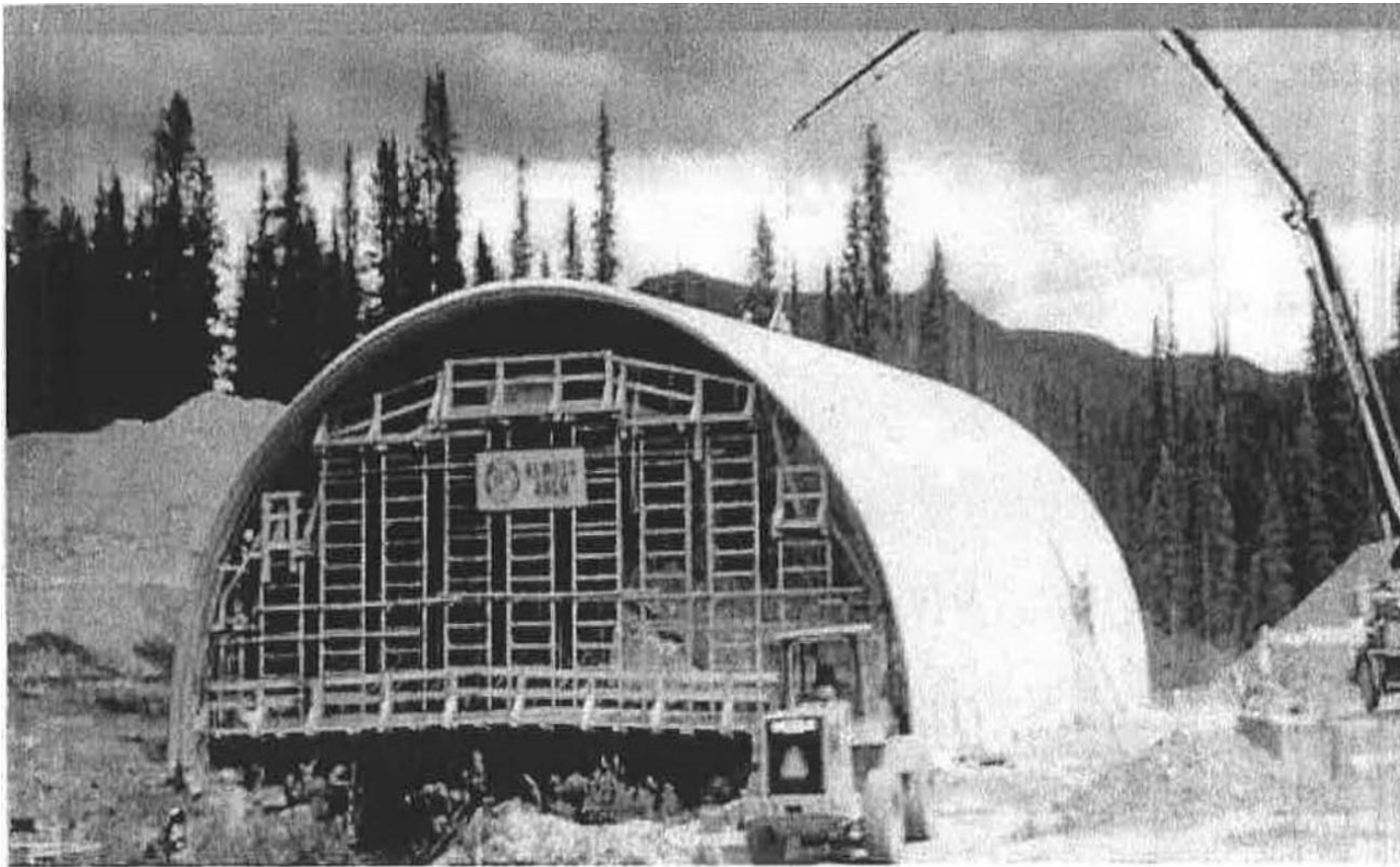

## Culvert Failure (Cont.)

### **Exposure for Failure to Warn (Cont.)**

*Just as there can be liability for making negligent statements, there can be liability for remaining silent when you have a duty to speak up.*

*When you know someone, to whom you owe a duty, is proceeding with a course of action that will be detrimental to them, you have a duty to speak up.*

*Surrey v. Carroll Hatch*

## Culvert Failure (Cont.)

### **Exposure for Failure to Warn (Cont.)**

- Design-build contractor hires bridge engineer to design a multi-plate culvert river crossing.
- Structure was initially designed with strip footing excavated into the riverbed.

# Culvert Failure (Cont.)

## Exposure for Failure to Warn (Cont.)

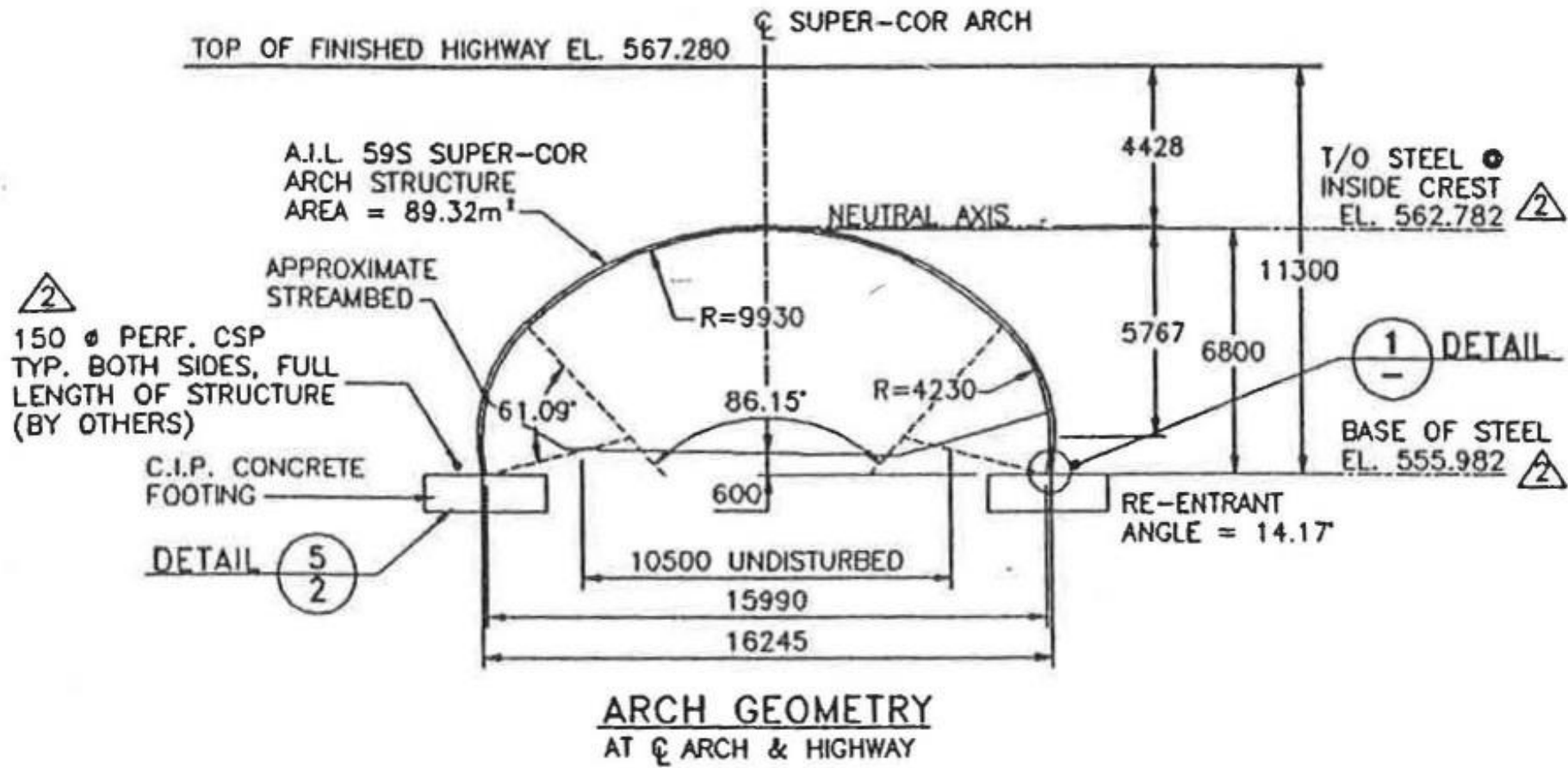

## Culvert Failure (Cont.)

### **Exposure for Failure to Warn (Cont.)**

- Department of Fisheries disapproves, and requires that foundation be 1 m back from the riverbank.
- Design-build contractor hires soil consultant to design pile foundations.

# Culvert Failure (Cont.)

## Exposure for Failure to Warn (Cont.)

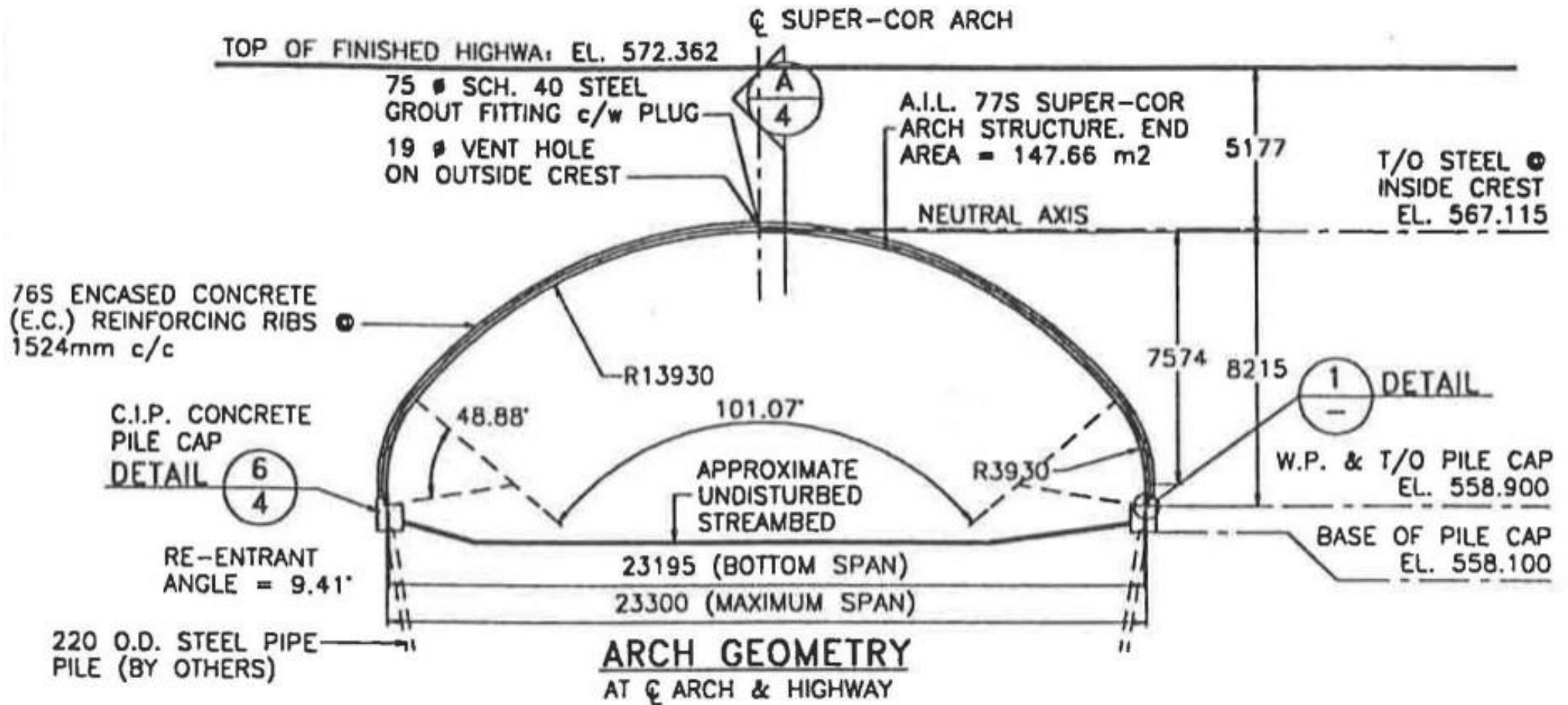

# Culvert Failure (Cont.)

## Exposure for Failure to Warn (Cont.)

ITEM	QTY	UNIT	DESCRIPTION	UNIT PRICE	TOTAL
1	35.05	m	<p>16.245m span 6.800m rise c/w assembly hardware, base channel, hook bolts for concrete footings and headwalls, and shop drawings</p> <p><b>Notes:</b></p> <ol style="list-style-type: none"> <li>1. Material supplied unassembled.</li> <li>2. Wingwalls supplied by owner.</li> <li>3. Structure designed as per criteria in specifications.</li> <li>4. Concrete footing design based on the allowable bearing capacity and minimum depth requirements below steamed as given in the specs. The footing elevation must be confirmed by the owner's or contractor's geotechnical engineer as to adequate depth for frost and scour protection.</li> <li>5. No temporary strutting or bracing required for arch during assembly and backfilling.</li> <li>6. No concrete thrust beams or reinforcing ribs are required.</li> </ol>	8700.00	304935.00
				<b>Total:</b>	<b>\$304,935.00</b>

Quotation firm for acceptance within 30 days

Culvert engineer's quote said that owner's or contractor's engineer must check for scour.

## Culvert Failure (Cont.)

### **Exposure for Failure to Warn (Cont.)**

- Pile designer never saw the culvert engineer's quote.
- Pile designer had no expertise in "scour" and was only asked to design the piles.
- Design-build contractor ignored the warning on the quote and did not hire anyone to look at scour - (A hydrogeomorphologist).
- Construction proceeded without anyone examining the impact of scour.

## Culvert Failure (Cont.)

### Exposure for Failure to Warn (Cont.)



# Takeaways

- Ensure that your scope of work is clear, say what you are not doing.
- If your scope of work changes, record the change.
- Ensure somebody competent is looking at all aspects of the project.
- Be particularly careful on design-built contracts where the design-build contractor is inexperienced or does not have the expertise to manage the consultants as well as the subcontractors.

CLYDE & CO

Successful risk navigation



Thank you. Any questions?

Vanessa Reakes, Partner

Vancouver

+1 604 408-2044

[vanessa.reakes@clydeco.ca](mailto:vanessa.reakes@clydeco.ca)

Clyde & Co LLP accepts no responsibility for loss occasioned to any person acting or refraining from acting as a result of material contained in this summary. No part of this summary may be used, reproduced, stored in a retrieval system or transmitted in any form or by any means, electronic, mechanical, photocopying, reading or otherwise without the prior permission of Clyde & Co LLP.

© Clyde & Co LLP 2025  
V2.25

Clyde & CoLLP

[www.clydeco.com](http://www.clydeco.com)